

APPENDIX A₁

SUMMARY OF MOMENT AND SHEAR FORCE

Summary of Maximum Moment Values Due to Loading	
(1/8 x Q x L²)	
Type of Moment	Value (kN.m)
MDC	10177,92664
MDW	1811,109375
MBR	57,69212949
MLL	2366,71875
MWS	1151,838422
MWL	184,78125
MEQ	1350,778602

Summary of Maximum Shear Values Due to Loading	
(1/2 x Q x L)	
Type of shear	Values (kN)
VDC	904,705
VDW	160,987
VBR	5,128
VLL	210,375
VWS	102,386
VWL	16,425
VEQ	120,069

APPENDIX A₂**SUMMARY OF MOMENT AND SHEAR FORCE (CONTINUE)**

Moment and Shear Values Due to Load Combination		
Type of load combination	Positive Moment at C	Shear at C
	KNm	N
Strength I	19681,79	1749,49
Strength II	18712,03	1663,29
Strength III	17051,65	1515,70
Strength IV	17983,55	1598,54
Strength V	19357,54	1720,67
Service I	14943,78	1328,34
Service II	15261,99	1356,62
Service III	13928,56	1238,09
Service IV	12795,32	1137,36
Extreme I	21758,74	1934,11
Extreme II	18002,06	1600,18
Fatigue I	3550,08	315,56
Fatigue II	1775,04	157,78

APPENDIX A₃

SUMMARY OF MOMENT AND SHEAR FORCE (CONTINUE)

Distance	Moment Due to Loading						
x	MDC	MDW	MLL	MBR	MWS	MWL	MEQ
0	0	0	0	0	0	0	0
4,5	4210,804	651,9994	852,0188	20,76917	414,6618	66,52125	486,2803
16,5	10864,91	1682,319	2198,419	53,58958	1069,93	171,6413	1254,723
28,5	10864,91	1682,319	2198,419	53,58958	1069,93	171,6413	1254,723
40,5	4210,804	651,9994	852,0188	20,76917	414,6618	66,52125	486,2803
45	0	0	0	0	0	0	0

Distance	Shear Force Due to Loading						
x	VDC	VDW	VLL	VBR	VWS	VWL	VEQ
0	1039,705	160,9875	210,375	5,128189	102,3856	16,425	120,0692
4,5	831,7637	128,79	168,3	4,102551	81,90851	13,14	96,05537
16,5	277,2546	42,93	56,1	1,367517	27,30284	4,38	32,01846
28,5	-277,255	-42,93	-56,1	-1,36752	-27,3028	-4,38	-32,0185
40,5	-831,764	-128,79	-168,3	-4,10255	-81,9085	-13,14	-96,0554
45	-1039,7	-160,988	-210,375	-5,12819	-102,386	-16,425	-120,069

APPENDIX A₄

LOAD COMBINATION (MOMENT)

Load Combination (Strength)				
Strength I	Strength II	Strength III	Strength IV	Strength V
0	0	0	0	0
7768,88	7419,77	6822,03	7294,20	7652,15
20045,63	19144,83	17602,52	18820,85	19744,44
20045,63	19144,83	17602,52	18820,85	19744,44
7768,88	7419,77	6822,03	7294,20	7652,15
0,00	0,00	0,00	0,00	0,00

Load Combination (Service)			
Service I	Service II	Service III	Service IV
0	0	0	0
5926,51	6041,07	5561,03	5153,07
15291,86	15587,44	14348,84	13296,18
15291,86	15587,44	14348,84	13296,18
5926,51	6041,07	5561,03	5153,07
0,00	0,00	0,00	0,00

Load Combination			
Extreme		Fatigue	
Extreme I	Extreme II	Fatigue I	Fatigue II
0	0	0	0
7600,57	7164,18	1278,03	639,01
19611,35	18485,35	3297,63	1648,81
19611,35	18485,35	3297,63	1648,81
7600,57	7164,18	1278,03	639,01
0,00	0,00	0,00	0,00

APPENDIX A₅

LOAD COMBINATION (SHEAR FORCE)

Load Combination (Strength)				
Strength I	Strength II	Strength III	Strength IV	Strength V
1918,243	1832,041	1684,4519	1801,038	1889,42055
1534,594	1465,633	1347,5615	1440,831	1511,53644
511,5314	488,5443	449,18717	480,2768	503,84548
-511,5314	-488,544	-449,18717	-480,2768	-503,84548
-1534,594	-1465,63	-1347,5615	-1440,831	-1511,5364
-1918,243	-1832,04	-1684,4519	-1801,038	-1889,4205

Load Combination (Service)			
Service I	Service II	Service III	Service IV
1463,336	1491,6214	1373,0946	1272,362
1170,669	1193,2971	1098,4757	1017,8896
390,2229	397,76571	366,15857	339,29654
-390,223	-397,7657	-366,1586	-339,2965
-1170,67	-1193,297	-1098,476	-1017,89
-1463,34	-1491,621	-1373,095	-1272,362

Load Combination			
Extreme		Fatigue	
Extreme I	Extreme II	Fatigue I	Fatigue II
1876,6844	1768,933	315,5625	157,7813
1501,3475	1415,146	252,45	126,225
500,44917	471,7154	84,15	42,075
-500,44917	-471,715	-84,15	-42,075
-1501,3475	-1415,15	-252,45	-126,225
-1876,6844	-1768,93	-315,563	-157,7813

APPENDIX B₁

RESULT OF CALCULATION AND ANALYSIS

Steel Box Girder Structure Review on Ultimate Moment Strength I			
Type	Stress Occurs (Mpa)	Stress Limit (Mpa)	Ratio
Local Buckling at the top flange	187,87	240	0,78
Lateral torsion buckling at the top flange	178,30	240	0,74
Flexure buckling at web plate	173,52	240	0,72
Tensile at the bottom flange	203,87	216	0,94

Steel Box Girder Structure Review on Service Condition (Service II)			
Type	Stress (Mpa) and Deflection (m) Occurs	Stress Limit (Mpa)	Ratio
Total stress at the top flange	138,70	228,00	0,61
Total stress at the bottom flange	163,69	228,00	0,72
Deflection due to live load	0,034	0,056	0,60

Structure Review on Ultimate Limit Condition			
Type	Force occurs	Stress Limit (Mpa)	Ratio
Moment	19681,79	39597,53	0,50
Shear Force	901,80	6343,75	0,14

APPENDIX B₂

RESULT OF CALCULATION AND ANALYSIS (CONTINUE)

Structure Review on Fatigue Limit Condition			
Type	Stress Occurs (Mpa)	Stress limit (Mpa)	Ratio
Stress due to fatigue load	17,95	34	0,53

Shear Connector		Stud Distance	40	cm
Splice	Web Plates	Total Bolt	40	Pcs
		Description	4	Row
			10	Pcs
	Bottom Flange	Total Bolt	84	Pcs
		Description	4	Row
			21	Pcs
	Top Flange	Total Bolt	60	Pcs
		Description	10	Row
			6	Pcs
Bracing		Profile	L 180 x 180 x 18	mm

APPENDIX C₁ -- SIDE VIEW OF BRIDGE DRAWING

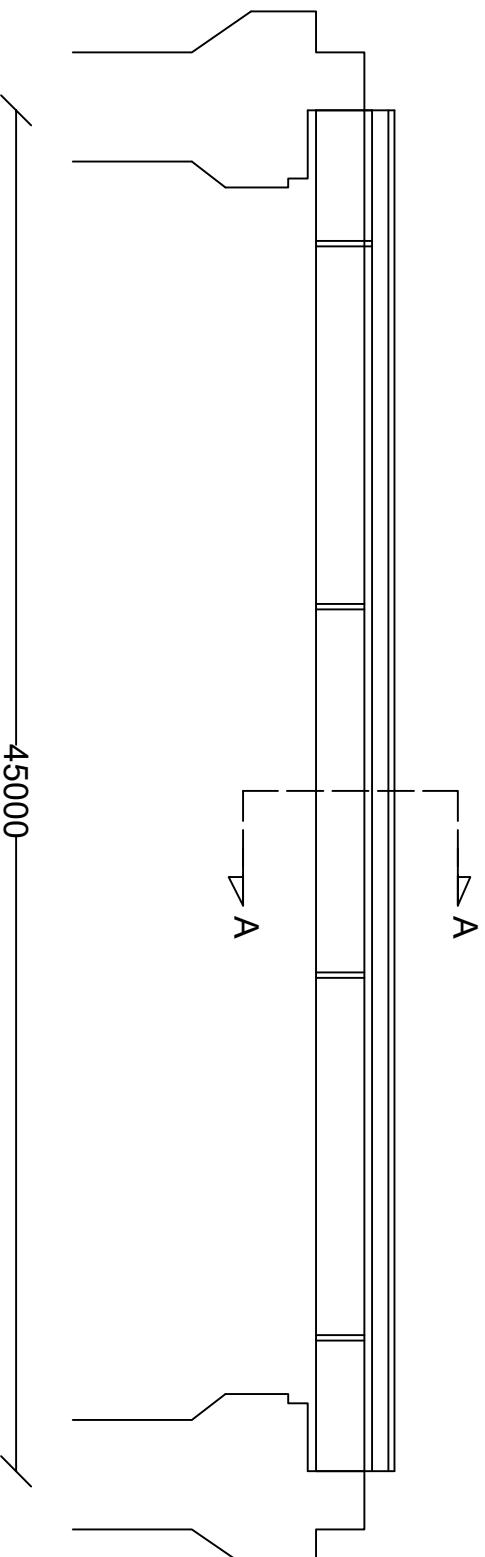

Side View of Bridge Drawing

FINAL ASSIGNMENT



DEPARTMENT OF CIVIL ENGINEERING
FACULTY OF ENGINEERING
SULTAN AGUNG ISLAMIC UNIVERSITY
SEMARANG

Supervisor

Ir. Gatot Rusbiantardjo, M.R.Eng.Sc., Ph.D

Co-Supervisor

Art Sentani, ST., MSc.

Drafted by:

MUHAMMAD AMINUDDIN NAJIB
30201504184

MUHAMMAD NAUFAL WIDODO
30201504199

Title of Drawing

Side View of Bridge Drawing

Number of Drawing	Total of Drawing
01	08
SCALE	1 : 250

APPENDIX C₂ --- TOP VIEW DRAWING OF THE BRIDGE

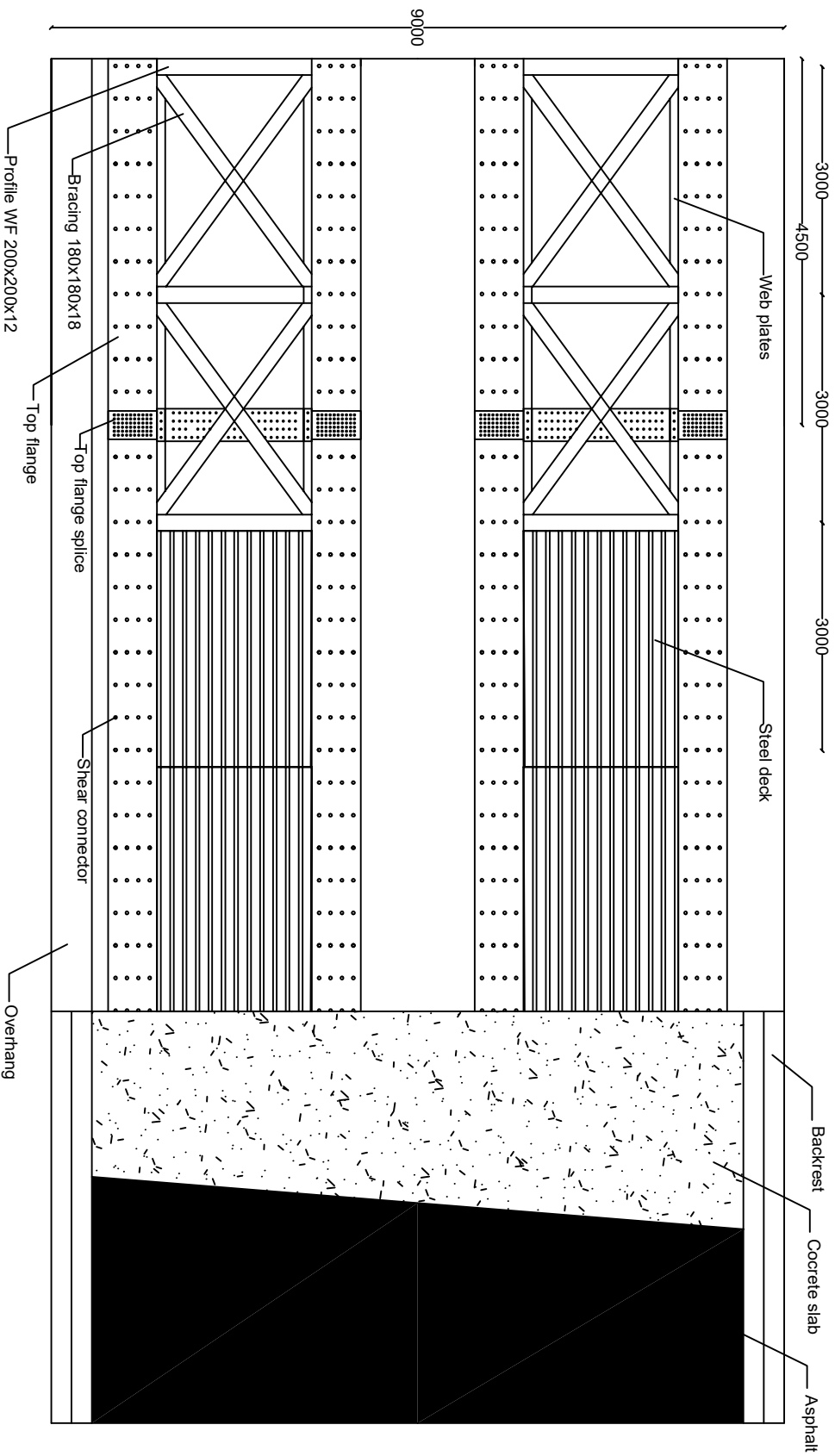

TOP VIEW DRAWING OF THE BRIDGE

FINAL ASSIGNMENT



DEPARTMENT OF CIVIL ENGINEERING
FACULTY OF ENGINEERING
SULTAN AGUNG ISLAMIC UNIVERSITY
SEMARANG

Supervisor

Ir. Gatot Rusbintarjo, M.R.Eng.Sc., Ph.D

Co-Supervisor

Art Sentani, ST., MSc.

Drafted by:

MUHAMMAD AMINUDDIN NAJIB
30201504184

MUHAMMAD NAUFAL WIDODO
30201504199

Title of Drawing

TOP VIEW DRAWING OF THE BRIDGE

Number of Drawing	Total of Drawing
02	08
SCALE 1 : 80	

APPENDIX C₃ -- CUT SECTION A-A DRAWING

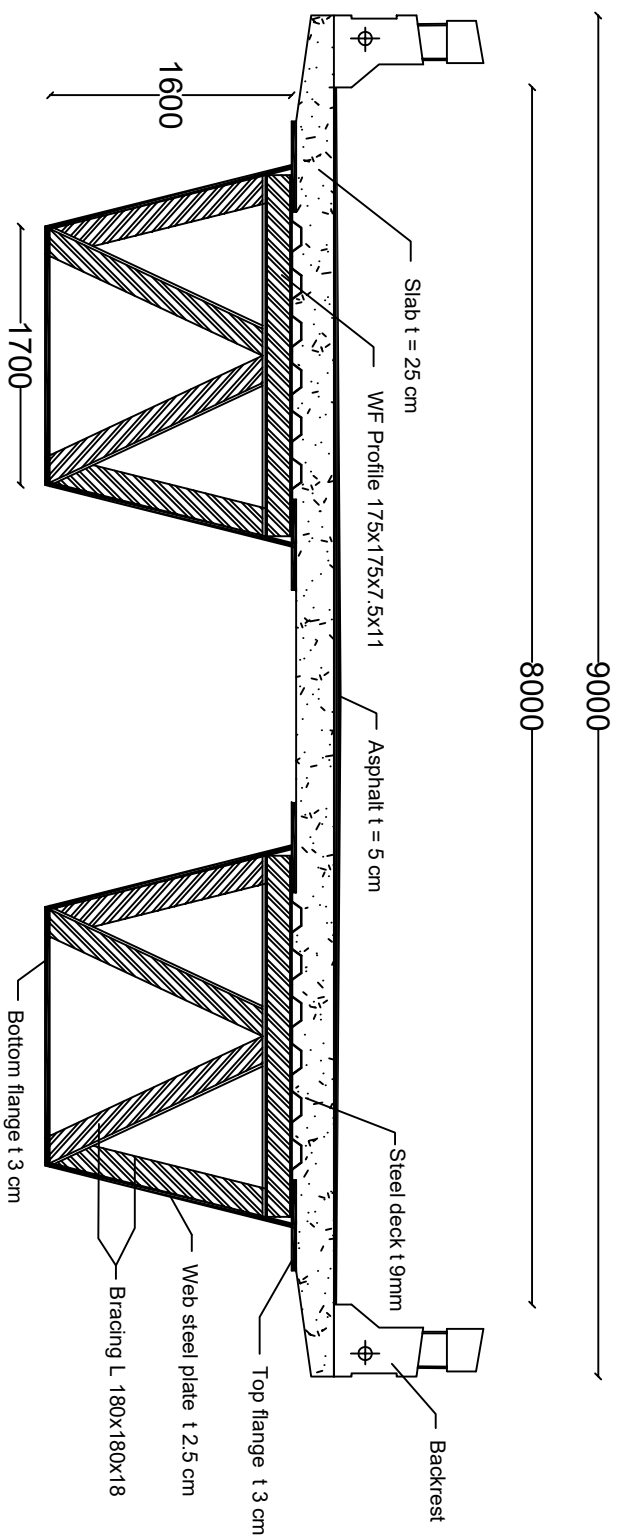

CUT SECTION A-A DRAWING

FINAL ASSIGNMENT



DEPARTMENT OF CIVIL ENGINEERING
 FACULTY OF ENGINEERING
 SULTAN AGUNG ISLAMIC UNIVERSITY
 SEMARANG

Supervisor

Ir. Gatot Rusbiantardjo, M.R.Eng.Sc., Ph.D

Co-Supervisor

Art Sentani, ST., MSc.

Drafted by:

MUHAMMAD AMINUDDIN NAJIB
 30201504184
 MUHAMMAD NAUFAL WIDODO
 30201504199

Title of Drawing

CUT SECTION A-A DRAWING

Number of Drawing	Total of Drawing
-------------------	------------------

03 08

SCALE 1 : 50

APPENDIX C₅ -- STEEL BOX GIRDER PROFILE

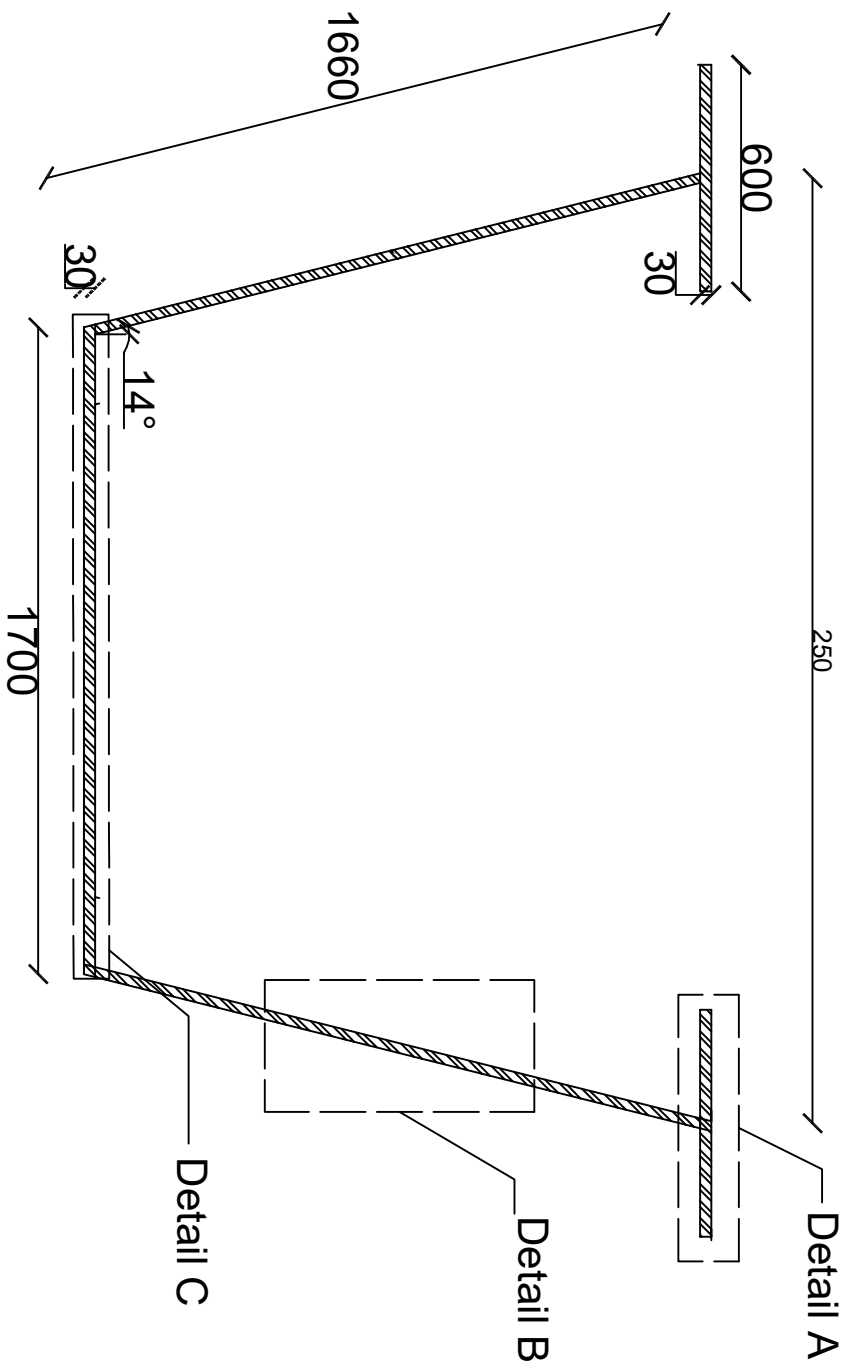

STEEL BOX GIRDER PROFILE

FINAL ASSIGNMENT



DEPARTMENT OF CIVIL ENGINEERING
 FACULTY OF ENGINEERING
 SULTAN AGUNG ISLAMIC UNIVERSITY
 SEMARANG

Supervisor

Ir. Gatot Rusbiantoro, M.R.Eng.Sc., Ph.D

Co-Supervisor

Ari Sentani, ST., MSc.

Drafted by:

MUHAMMAD AMINUDDIN NAJIB
 30201504184

MUHAMMAD NAUFAL WIDODO
 30201504199

Title of Drawing

STEEL BOX GIRDER PROFILE

Number of Drawing	Total of Drawing
05	08

SCALE 1 : 200

APPENDIX C7 -- DETAIL B

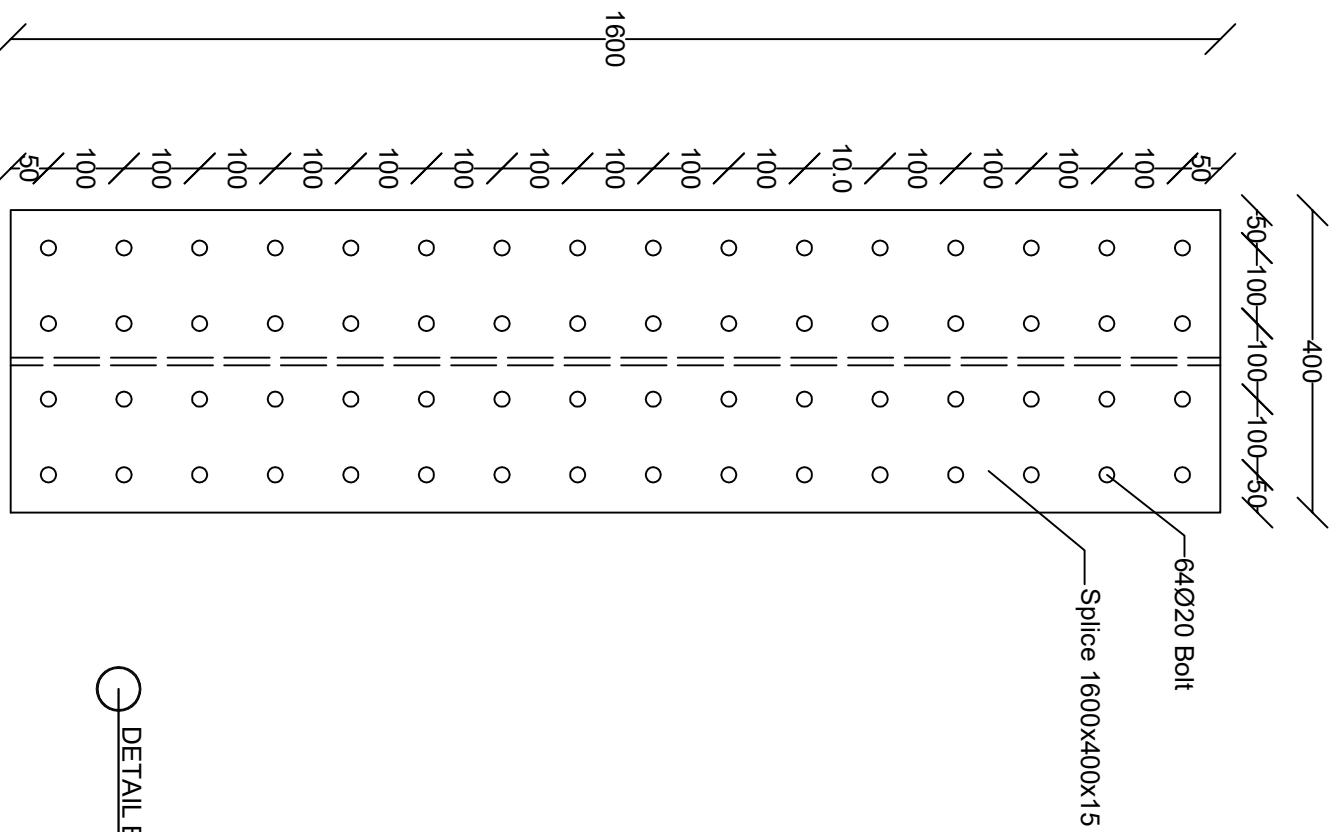

DETAIL B

FINAL ASSIGNMENT



DEPARTMENT OF CIVIL ENGINEERING
 FACULTY OF ENGINEERING
 SULTAN AGUNG ISLAMIC UNIVERSITY
 SEMARANG

Supervisor

Ir. Gatot Rusbiantardjo, M.R.Eng.Sc., Ph.D

Co-Supervisor

Ari Sentani, ST., MSc.

Drafted by:

MUHAMMAD AMINUDDIN NAJIB
 30201504184

MUHAMMAD NAUFAL WIDODO
 30201504199

Title of Drawing

DETAIL B

Number of Drawing	Total of Drawing
07	08
SCALE	1 : 10

APPENDIX C₈ -- DETAIL C

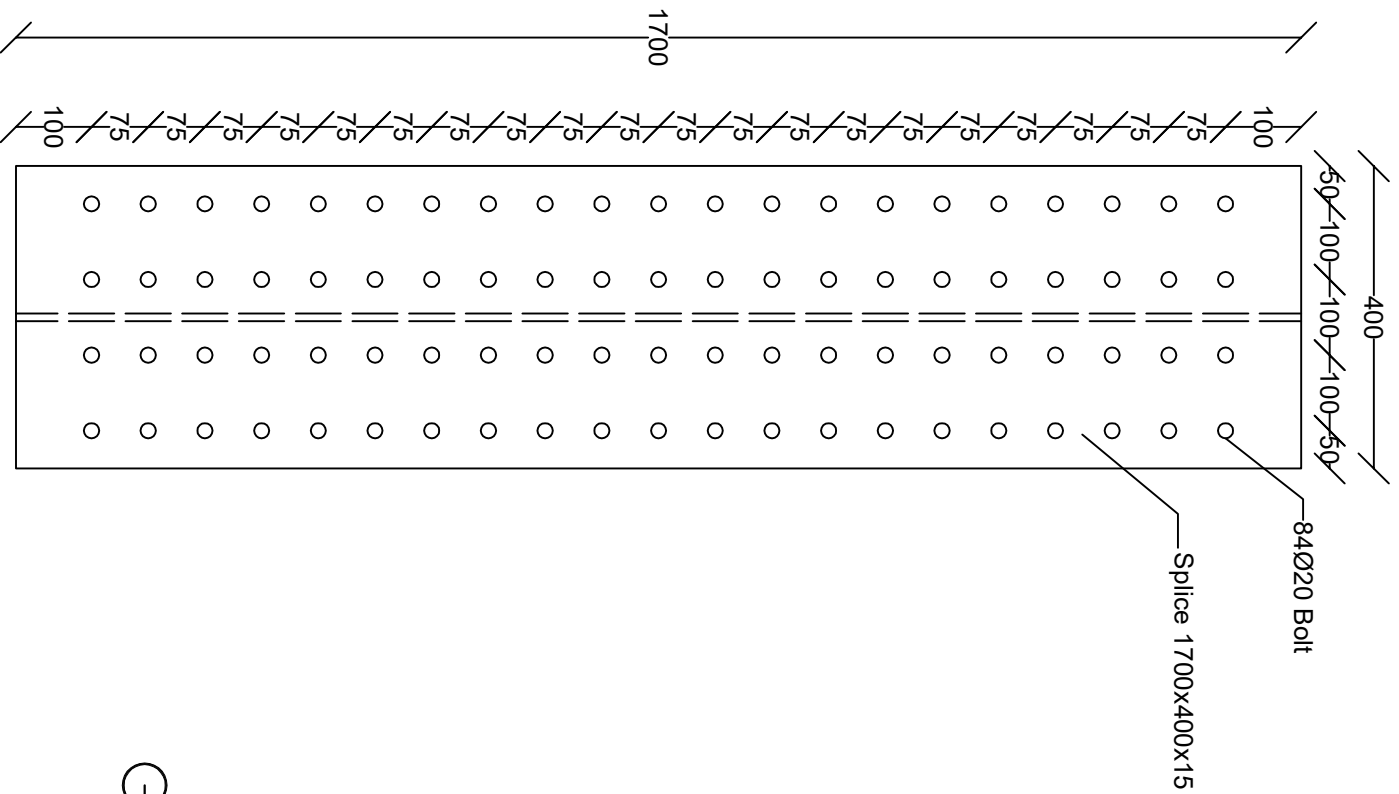

⊙ DETAIL C

FINAL ASSIGNMENT



DEPARTMENT OF CIVIL ENGINEERING
 FACULTY OF ENGINEERING
 SULTAN AGUNG ISLAMIC UNIVERSITY
 SEMARANG

Supervisor

Ir. Gatot Rusbiantardjo, M.R.Eng.Sc., Ph.D

Co-Supervisor

Ari Sentani, ST., MSc.

Drafted by:

MUHAMMAD AMINUDDIN NAJIB
 30201504184

MUHAMMAD NAUFAL WIDODO
 30201504199

Title of Drawing

DETAIL C

Number of Drawing	Total of Drawing
08	08
SCALE 1 : 10	